

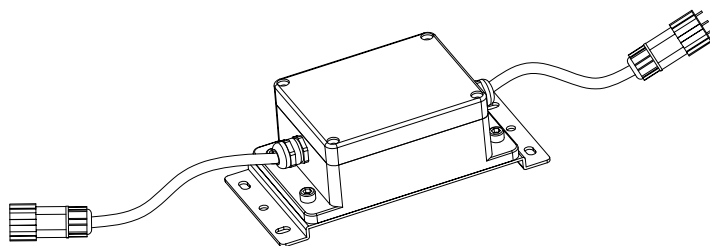

Blue Plug & Play daylight relay



OMKOPPLING FRÅN SKYMNING TILL GRYNING

MS02 är lämpligt för inbyggnation i alla typer av LED-belysningsarmaturer. Det tänds och släcker belysningen från skymning till gryning.



1 Slår automatiskt på ljuset vid skymning.

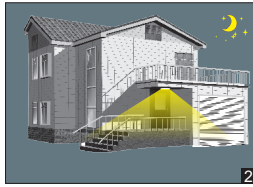

2 Lyser kontinuerligt genom natten.



3 Släcker automatiskt ljuset vid gryning.

Obs! MS02 är avsett endast för LED-belysningsarmaturer (det får inte användas tillsammans med wolfram- eller halogenlampor). Om det används i lysrörsarmaturer måste dess funktion testas.

KOPPLINGSSCHEMA

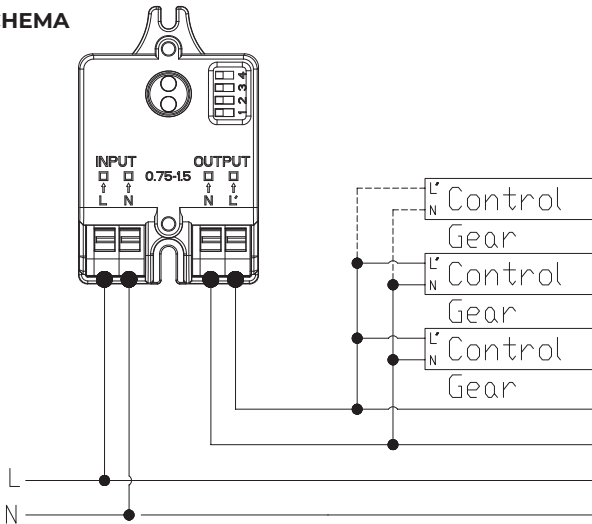

INSTÄLLNING

Tändning/släckning kan ställas in (med DIP-omkopplare) efter omgivningens belysningsstyrka.

NATTSENSOR

När omgivningsbelysningen understiger inställd belysningsstyrka aktiverar sensorn automatiskt belysningen på 100 % ljusstyrka. När omgivningsbelysningen överstiger inställd belysningsstyrka släcks belysningen.

	1	2	3	4	open	close
I	ON	ON	ON	ON	5Lux	25Lux
II	ON	ON	ON	-	10Lux	50Lux
III	ON	ON	-	ON	25Lux	75Lux
IV	ON	ON	-	-	50Lux	100Lux
V	ON	-	ON	-	100Lux	200Lux
VI	ON	-	-	-	150Lux	300Lux
VII	-	ON	-	-	200Lux	400Lux
VIII	-	-	-	-	Disable	



TEKNISKA DATA

Beskrivning:	Skymningsrelä Blue Plug & Play
Artikelnummer:	EB15001
Spänning:	220–240 VAC
Max. effekt/ström:	2900 W/250 A
Kapslingsklass:	IP65
Drifttemperatur:	-20 till +40 °C
Kabel:	H07RN-F med snabbkoppling (M19 och M25)
Material:	Polykarbonat
Mått:	190 x 190 x 55

DAG/NATT-BRYTER

MS02 er egnet for å bygge inn alle typer LED-lysarmaturer og slår på/av lyset fra skumring til morgengry.



Slår automatisk av lyset ved skumring.



Lyser kontinuerlig gjennom natten.



Slår av lyset ved morgengry.

Merk: Etersom MS02-releet er designet for LED-lysarmaturer, kan det ikke brukes med wolfram- og halogenpærer. Faktisk effekt ved innbygging i fluorescerende armaturer bør testes.

KABLINGSDIAGRAM

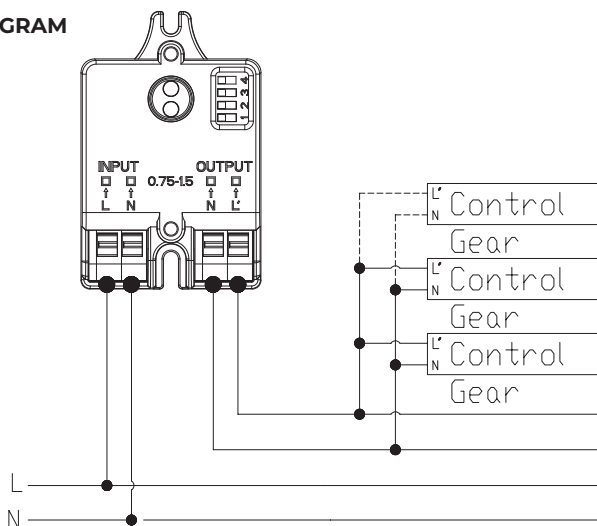

INNSTILLING

Ved å velge en kombinasjon av DIP-brytere kan man stille inn lux-nivået som påkrevd.

NATTLYSSENSOR

Når nivået på det naturlige lyset er lavere enn det åpne lux-nivået, slår sensoren automatisk på lyset med 100 % lysstyrke. Når nivået på det naturlige lyset er høyere enn det lukkede lux-nivået, slår sensoren av lyset.

	1	2	3	4	open	close
I	ON	ON	ON	ON	5Lux	25Lux
II	ON	ON	ON	-	10Lux	50Lux
III	ON	ON	-	ON	25Lux	75Lux
IV	ON	ON	-	-	50Lux	100Lux
V	ON	-	ON	-	100Lux	200Lux
VI	ON	-	-	-	150Lux	300Lux
VII	-	ON	-	-	200Lux	400Lux
VIII	-	-	-	-	Disable	



TEKNISKE DATA

Beskrivelse:	Blue Plug & Play dagslysrelé
Artikkelnummer:	EB15001
Spenning:	220–240 VAC
Maks. belastning:	2900 W / 250 A
IP-klassifisering:	IP65
Arbeidstemperatur:	-20 til +40 °C
Kabel:	H07RN-F med hurtigkoblinger (M19 og M25)
Materiale:	Polykarbonat
Dimensjoner:	190 x 190 x 55

YÖVALON KYTKENTÄÄN

MS02 sopii kaikentyyppisiin LED-valaisimiin, ja se sytyttää ja sammuttaa valon ilta- ja aamuhämärässä.



1 Sytyttää valon automaattisesti iltahämärässä.

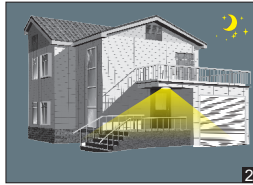

2 Valaisee läpi yön.



3 Sammuttaa valon päältä aamuhämärässä.

Huom: Koska MS02 on suunniteltu LED-valaisimiin, sitä ei voida käyttää volframi- ja halogeenivalaisimissa. Todelliset vaikutukset loisteputkivalaisimiin asennettuna on testattava uudelleen.

KYTKENTÄKAAVIO

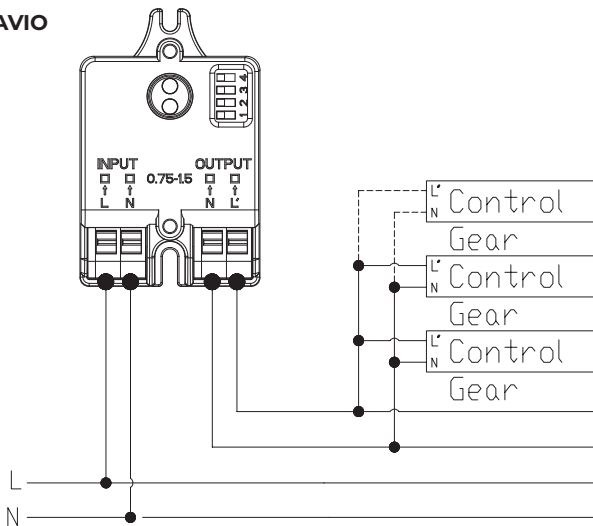

ASETUS

DIP-kytkimien eri yhdistelmillä ON/OFF-kytkennän valonvoimakkuustaso voidaan asettaa vaatimusten mukaan.

YÖVALOTUNNISTINTOIMINTO

Kun ympäröivän valon taso alittaa valon sytytykselle asetetun valonvoimakkuustason, tunnistin sytyttää valot automaattisesti 100 % kirkkaudella. Kun ympäröivän valon taso alittaa sammutuksen valonvoimakkuustason, valot sammutetaan.

	1	2	3	4	open	close
I	ON	ON	ON	ON	5Lux	25Lux
II	ON	ON	ON	-	10Lux	50Lux
III	ON	ON	-	ON	25Lux	75Lux
IV	ON	ON	-	-	50Lux	100Lux
V	ON	-	ON	-	100Lux	200Lux
VI	ON	-	-	-	150Lux	300Lux
VII	-	ON	-	-	200Lux	400Lux
VIII	-	-	-	-	Disable	



TEKNISET TIEDOT

Kuvaus:	Blue Plug & Play-päivänvalorele
Tuotenumero:	EB15001
Jännite:	220–240 VAC
Suurin kuorma:	2 900 W / 250 A
IP-luokitus:	IP65
Käyttölämpötila:	-20 - +40°C
Kaapeli:	H07RN-F pikaliittimillä (M19 & M25)
Materiaali:	Polykarbonaatti
Mitat:	190 x 190 x 55

DUSK-TO-DAWN SWITCHING

MS02 is suitable to built-in all type of LED lighting fixture and switches on/off lights till dusk to dawn.



1 Automatically turn on the light at dusk.



2 Stay illuminating continuously through the night.

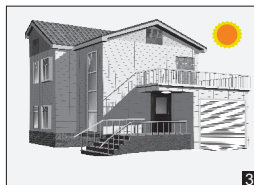

3 Switch off the light at dawn

Note: As MS02 is designed for LED lighting fixtures, it not applicable to tungsten and halogen lamp. Actually effects when built in fluorescent fixtures should be re-testing.

WIRING SCHEME

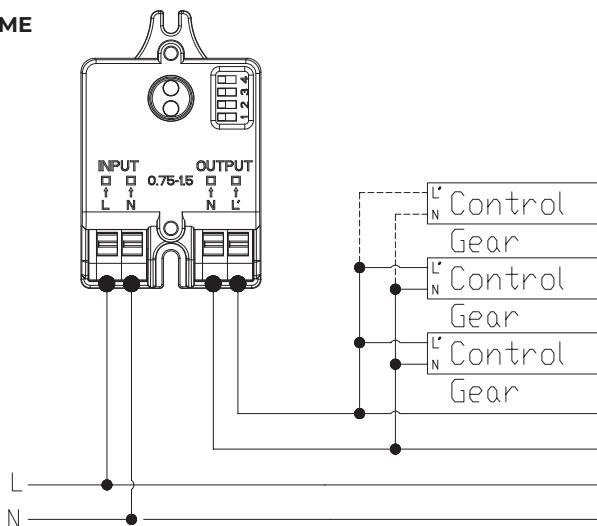

SETTING

By selecting the combination of the DIP switches, switching ON/OFF lux level can be set as requirement.

NIGHT LIGHT SENSOR FUNCTION

When ambient light level is below open lux level, sensor automatically switches on lights at 100% brightness. When ambient light level is over close lux level, it switches off lights.

	1	2	3	4	open	close
I	ON	ON	ON	ON	5Lux	25Lux
II	ON	ON	ON	-	10Lux	50Lux
III	ON	ON	-	ON	25Lux	75Lux
IV	ON	ON	-	-	50Lux	100Lux
V	ON	-	ON	-	100Lux	200Lux
VI	ON	-	-	-	150Lux	300Lux
VII	-	ON	-	-	200Lux	400Lux
VIII	-	-	-	-	Disable	

TECHNICAL DATA

Description:	Blue Plug & Play daylight relay
Item number:	EB15001
Voltage:	220–240 VAC
Max. load:	2,900 W / 250 A
IP rating:	IP65
Working temperature:	-20 to +40°C
Cable:	H07RN-F with quick connectors (M19 & M25)
Material:	Polycarbonate
Dimensions:	190 x 190 x 55

El-Björn AB

Box 29, SE-334 21 Anderstorp, Sweden, +46 (0)371-588 100
info@elbjorn.se, www.elbjorn.com

